

# Design and Implementation of a Fire Detection and Extinguishing System Using Dual Axis Mechanics

Sharul Hidayat Teknik Elektro Universitas Islam Negeri Sultan Syarif Kasim Riau Pekanbaru, Indonesia 12050513410@students.uin- suska.ac.id	Putut Son Maria Teknik Elektro Universitas Islam Negeri Sultan Syarif Kasim Riau Pekanbaru, Indonesia putut.son@uin- suska.ac.id	Hilman Zarory Teknik Elektro Universitas Islam Negeri Sultan Syarif Kasim Riau Pekanbaru, Indonesia hilman.zarory@uin- suska.ac.id	Ahmad Faizal Teknik Elektro Universitas Islam Negeri Sultan Syarif Kasim Riau Pekanbaru, Indonesia ahmad.faizal@uin- suska.ac.id
---	---	---	---

**Abstract**— Fire detection and extinguishing systems play an essential role in anticipating the impact of more severe damage to residential installations, warehouses, and buildings that store valuable goods or important documents. This research develops an automatic fire detection and extinguishing system using the dual-axis rotational principle. The flame channel sensor is used by modifying its default position to be collateral (facing the same plane at the same angle). The dual-axis principle allows panning and tilting movements to yield a broader scope for detecting and extinguishing fires. The Dual Axis built in the research has a panning angle range of  $113^\circ$  and a tilting angle of  $45^\circ$ . The results show good performance with a fire detection accuracy rate of 73-100% and a successful extinguishing rate of 76-96%. The implementation of dual-axis rotational construction in the automatic fire extinguishing system not only improves the detection coverage but also increases the chance ratio of more targeted extinguishing.

**Keywords**— *Dual axis, Fire detection, Fire extinguisher*

## I. INTRODUCTION

The rapid development of science and technology has brought various advances that are utilized to meet various human needs [1][2]. This progress can be seen from the large number of pieces of equipment created, both operated by manual control and automatic control systems. Automatic control systems improve the dynamic system so that it produces output signals as designed and desired[3]. This technology not only increases operational efficiency but is also able to provide innovative solutions to various technical problems [4].

Arduino Uno is a microcontroller board with an Atmel IC chip and AVR processor designed to make it easier to create and use electronic devices. The advantages include ease of programming with unique languages, flexibility in applications, and a broad community for support and development[5][6]. Arduino Uno is also an interactive physical computing system that uses hardware and software to detect and respond to environmental conditions. The Arduino Uno open-source license standard includes circuit schematics, PCB designs, bootloader firmware, documents and software[7]. The use of appropriate sensors, such as the 5-way flame sensor, has a big influence on the system to be designed. This sensor utilizes five infrared (IR) receivers and five indicator led to detect flames using optical methods at wavelengths of 760 nm to 1100 nm and converts the results into analogue quantities This sensor can read the intensity of light in a fire using infrared with a range of up to 50 cm. The combination

of Arduino Uno and this sensor allows the development of a more efficient and effective fire detection system.

In an effort to increase the accuracy and efficiency of a fire detection and extinguishing system, this research conducted an experimental study by designing a fire detection and extinguishing design using the Axis Rotational concept. This system allows the process of detecting and extinguishing fires more precisely using two axes of rotation (horizontal and vertical) [8]. This tool is inspired by the principle of a dual-axis solar tracker, which can find more optimal light points [9]. The use of Dual axis principle has high accuracy and freedom of tracking when used in solar tracker design; the angles that can be tracked in a solar tracker that uses this principle are the azimuth and altitude angles, while the single axis principle is only one of them [10][11].

The Dual Axis principle itself will be combined with an Arduino Uno as a microcontroller and added with a fire sensor, as well as several other supporting components such as a water pump, buzzer, relay and LED indicator. The Dual Axis principle itself will be implemented by using 2 servo units, each positioned horizontally and vertically[12][13].

In this research, a dual-axis mechanical construction is used as a support base for the sensor box. The dual-axis drive uses a servo that is installed in such a way that the sensor box can be controlled so that the azimuth and altitude directions are flexible enough to adjust to the presence of hotspots. The sensor used uses a modified flame sensor KIT, and the controller uses an Arduino Uno. In this research, the control program algorithm uses an average calculation formulation for fire detection[14][15].

## II. RESEARCH METHODOLOGY

### A. Hardware Design

Figure 1 shows the hardware design block diagram. The controller used is Arduino Uno. There are four actuators, with servo x and servo y as drivers. The buzzer functions as a warning indicator, and the relay supplies voltage to the pump. The use of Arduino as a microcontroller can improve the performance of devices, making them more efficient, because Arduino is a practical microcontroller[16][17].

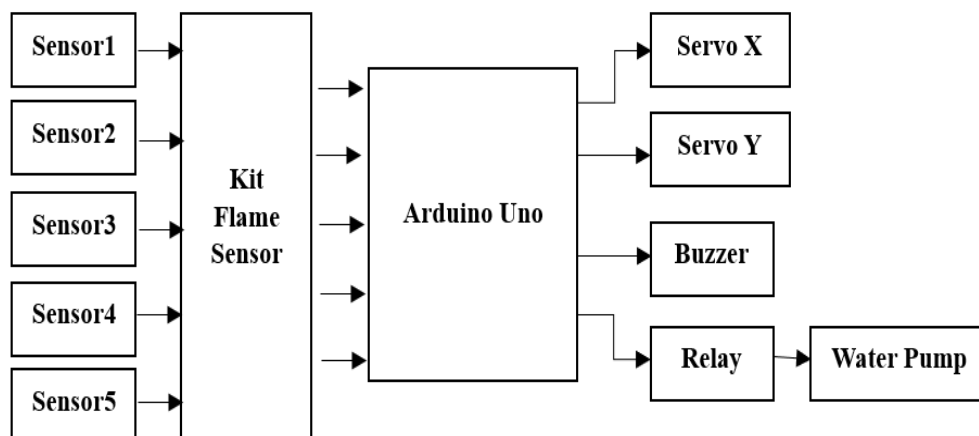

Figure 1. Hardware Block Diagram

Figure 2 is a wiring diagram for the electro-mechanical system. The separated sensor position configuration is not attached to the flame sensor KIT, but each sensor is

installed in a sensor box attached to the mechanical housing. Then, the sensor is connected using a cable to the flame sensor KIT.

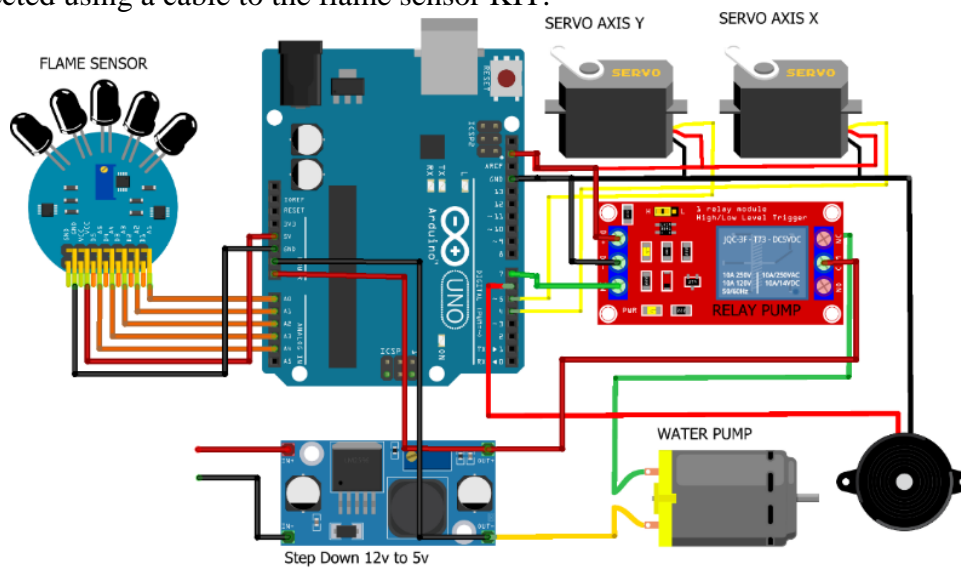

Figure 2. Wiring Diagram.

The physical model of the entire system is shown in Figure 3. The model has a height of 30 cm with an X side of 30 cm and a Y side of 10 cm. On the right, there is a box for storing water and a hose that channels the water to the water pump. In the circuit box, there are several components, such as an Arduino Uno, a buzzer, a water pump, a fire sensor module, and a relay. On the left, there is a power supply as a voltage provider for the entire system.

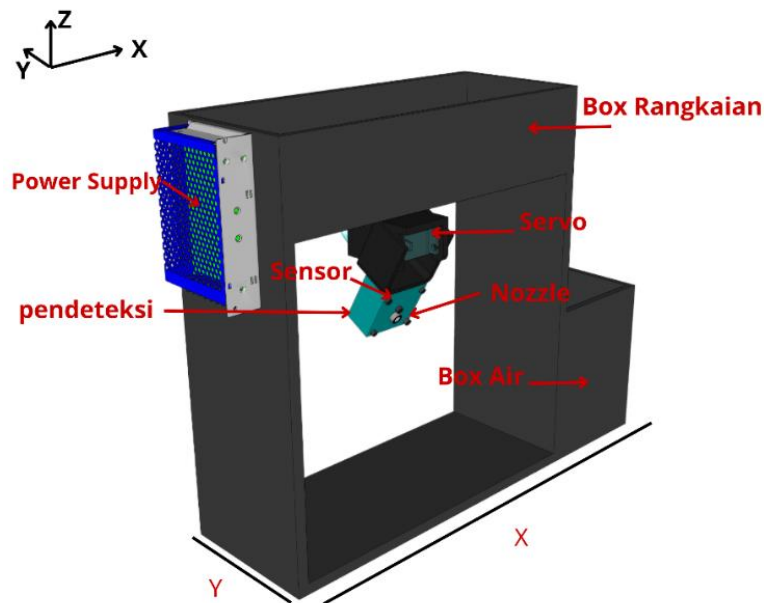

Figure 3. Physical Design Sketch

Side X is the front side of the fire extinguisher, and side Y is the side of the fire extinguisher. Servo X will move the sensor housing and rotate panning (left-right and

vice versa), while servo Y will move the sensor housing tilting (up-down and vice versa).

### B. Dual Axis System Design

The use of this dual-axis system aims to enlarge the coverage area of the sensor for detection[18][19].The sensor is installed in a small box, as shown in Figure 4. The sensor box contains 5 fire sensors and a nozzle that is connected to a water hose. Servo X will move the sensor housing panning (left, right, or vice versa). Then, servo Y will move the sensor housing tilting (up and down or vice versa). The origin position on the sensor box is servo Y at an angle of 45° and servo X at an angle of 90°.

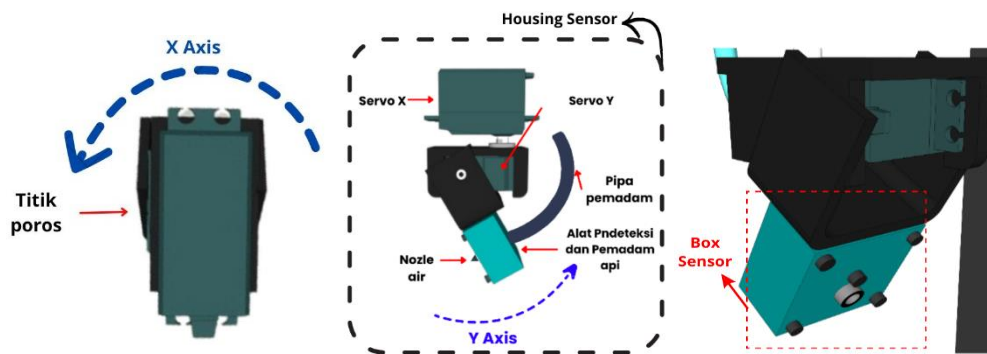

Figure 4. Dual Axis Movement

### C. Software Design

The purpose of software design is to develop the working algorithm of a system to ensure that the system functions according to the design[20]. Figure 5 shows the sensor numbering. The sensor's Standby position is at an angle of 45 relative to the horizontal plane. The value of each sensor is stored in a different variable for the detection algorithm.

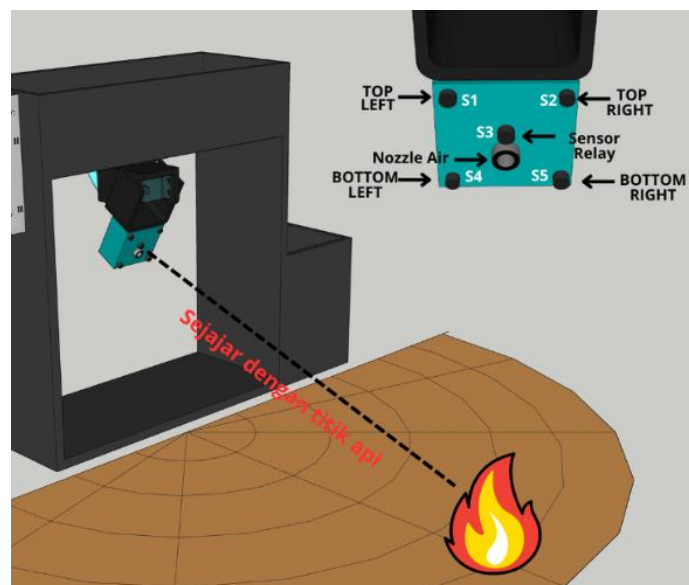

Figure 5. Relay Activation Sensor Aligned With The Flame

The flow diagram of the fire detection and extinguishing program is shown in Figure 6.

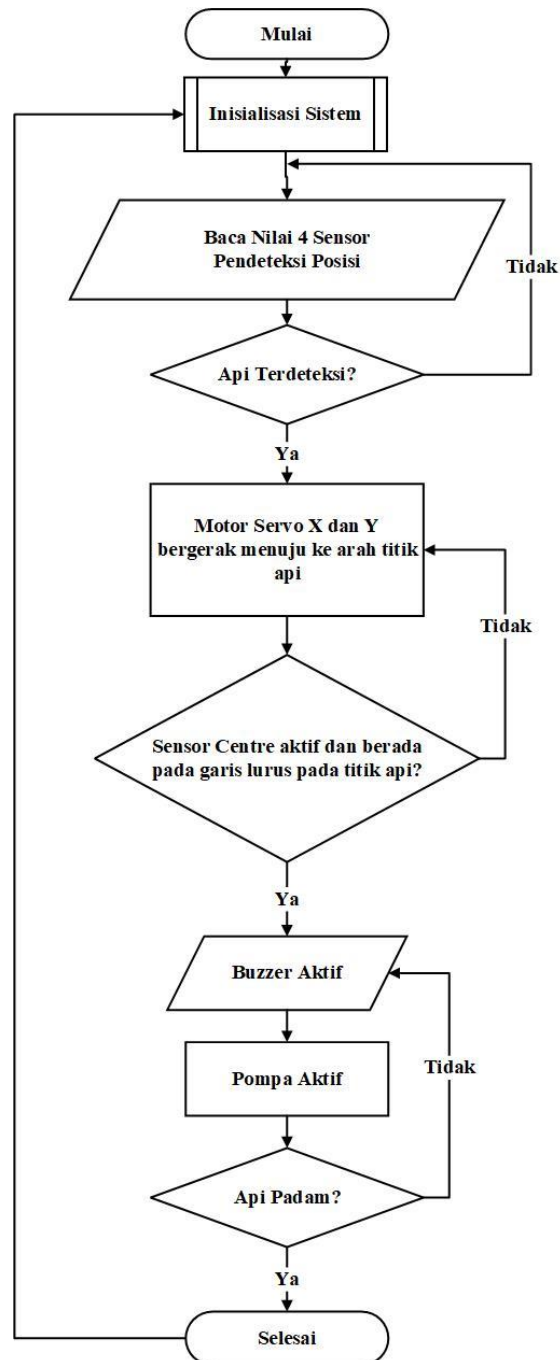

Figure 6. Software Flowchart

The fire detection algorithm is calculated from the readings of 4 sensors, namely lt, rt, ld and rd. The average value of the up-down and left-right sensor readings is used as a reference for the program to move the servo by an offset angle so that the housing moves in a direction approaching the fire point angle. The variables that are related to the sensor position are :

- **lt**: Top left sensor.
- **rt**: Top right sensor.
- **ld**: Bottom left sensor.
- **rd**: Bottom right sensor.

The formula for calculating the average left-right sensor and top-bottom sensor is:

**avt (average top):** The average value of the top left and top right sensors.

$$Avt = \frac{lt+rt}{2} \quad (1)$$

**avd (average down):** The average value of the bottom left and bottom right sensors.

$$Avd = \frac{ld+rd}{2} \quad (2)$$

**avl (average left):** The average value of the top left and bottom left sensors

$$Avl = \frac{lt+ld}{2} \quad (3)$$

**avr (average right):** The average value of the top right and bottom right sensors

$$Avr = \frac{rt+rd}{2} \quad (4)$$

To calculate the difference or discrepancy between the average sensor values, the following formula can be used:

- **dvert (difference vertical):** The difference between the average values of the top and bottom sensors.

$$dvert=avt-avd \quad (5)$$

- **dhoriz (difference horizontal):** The difference between the average values of the left and right sensors.

$$dhoriz=avl-avr \quad (6)$$

Tolerance is the limit value that determines whether servo movement is necessary. In this system, the tolerance value is 20, but it can be adjusted according to needs.

#### **Vertical Servo Movement:**

- If the vertical difference (dvert) is greater than the tolerance:
  - If the top average value (avt) is greater than the bottom average value (avd):
    - Decrease the vertical servo angle (servov) by 3 degrees.
    - Ensure the angle value is not less than the lower limit (servovLimitLow).
  - If the top average value (avt) is less than the bottom average value (avd):
    - Increase the vertical servo angle (servov) by 3 degrees.
    - Ensure the angle value does not exceed the upper limit (servovLimitHigh).

#### **Horizontal Servo Movement:**

- If the horizontal difference (dhoriz) is greater than the tolerance:
  - If the left average value (avl) is greater than the right average value (avr):
    - Increase the horizontal servo angle (servoh) by 3 degrees.
    - Ensure the angle value does not exceed the upper limit (servohLimitHigh).
  - If the left average value (avl) is less than the right average value (avr):

- Decrease the horizontal servo angle (servoh) by 3 degrees.
- Ensure the angle value does not fall below the lower limit (servohLimitLow).

Considering the predetermined tolerance limits, this formula regulates how the two servos move based on the average sensor value and the resulting difference. If the sensor centre is parallel to the fire point, the buzzer and relay are active to open voltage to the water pump to extinguish the fire..

### III. RESULTS AND DISCUSSION

All necessary components, such as Arduino Uno, flame sensor, buzzer, relay, water pump, servo and power supply, are assembled and put in a PVC box so that the components are protected and do not interfere with the system when it is running. The prototype can be seen in Figure 7.



Figure 7. Prototype of an Automatic Fire Detection and Extinguishing System

#### A. Flame Sensor Testing

Flame sensor testing is carried out to determine the value and characteristics of the five flame sensors. This test will be carried out by varying the number of fire points, namely one fire point, two fire points, and three fire points. This test will be carried out at different distances, starting from 5. cm to 30 cm with intervals of 5 cm. Every time you start a test, the program sets the initial position of the sensor box to be at the origin coordinates.



1 Point of fire



2 Point of fire

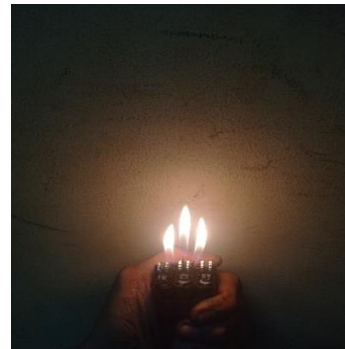

3 Point of fire

Figure 8. Variations in the number of fire points tested

Figure 10 shows the characteristics of sensor testing at one hotspot, two hotspots, and three hotspots. The characteristic pattern of all sensors shows a negative gradient. The output values from the sensors vary even though the type of infrared sensor device used uses the same part number. The difference in sensor reading values from variations in the number of hotspots was insignificant, but all sensors showed symptoms of a more coherent distribution of sensor reading values..

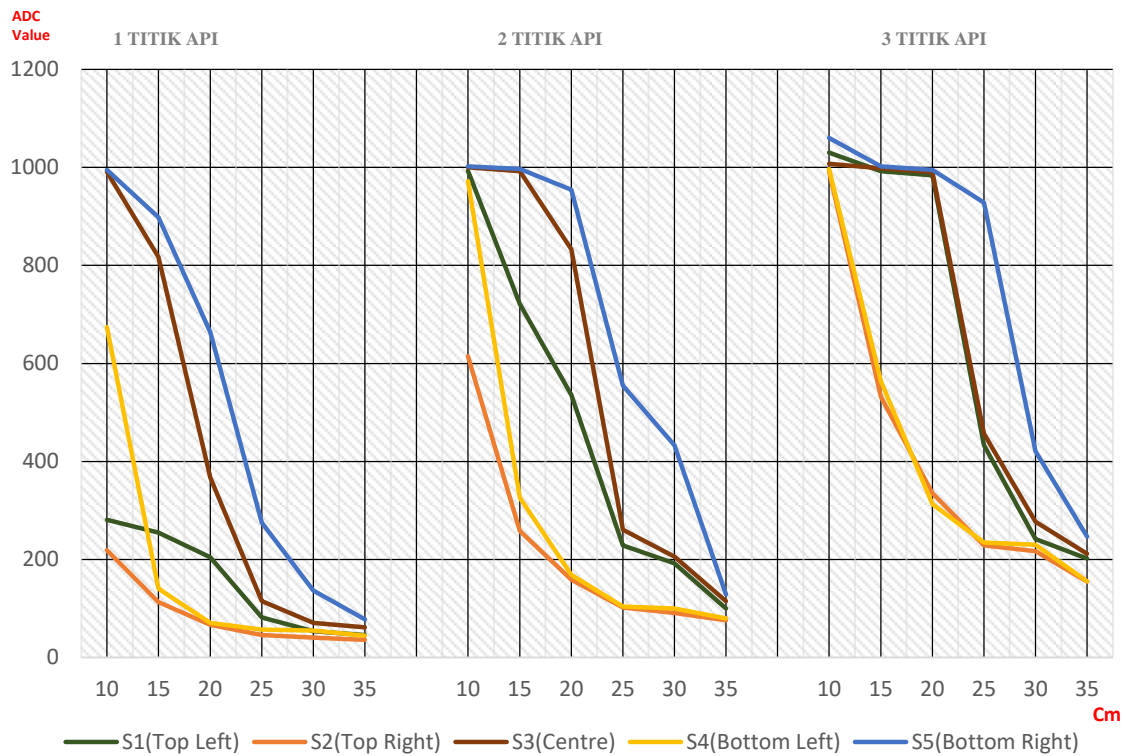

Figure 9. Graph of flame sensor characteristics

### B. Testing of Fire Detector and Extinguisher with Dual Axis Principle

Testing fire detectors and extinguishers are carried out by varying the number of fire points, distance, and angle of the fire points to the sensor. When this tool is activated, the detection program starts taking readings and calculations or determining fire detection. If the fire is detected, the sensor housing moves to the fire point and the water pump activates and shoots water..

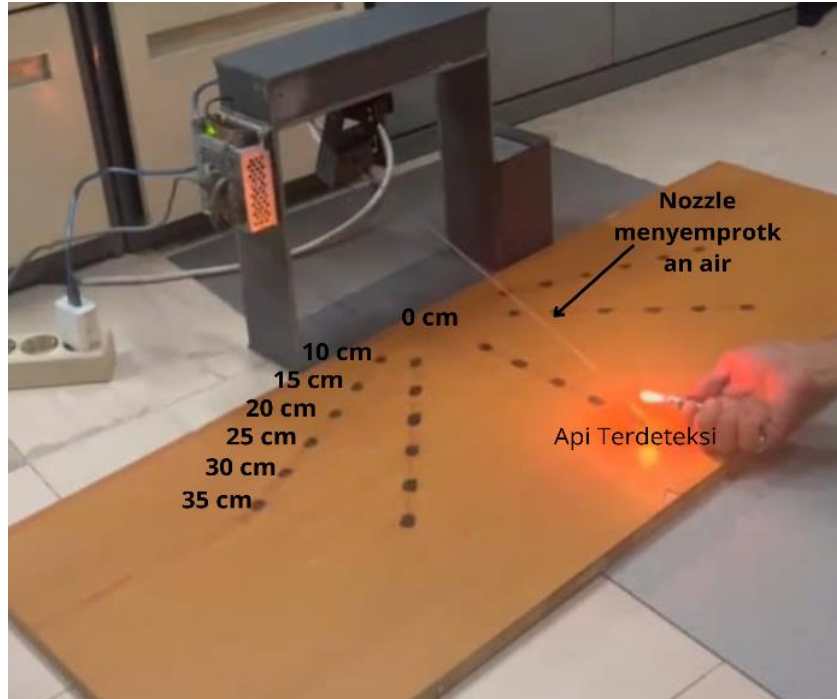

Figure 10. Process of testing the device

The results of testing by varying the distance, angle, and number of fire points are shown in Table 1.

Table 1. Results of Testing the Fire Detector and Extinguisher with Dual Axis Principle.

Jenis Api	Jarak ( Cm)	Sudut				
		22°	45°	90°	112°	135°
1 Titik Api	10	TDP	TDP	TDP	TDP	TDP
	15	TDP	TDP	TDP	TDP	TDP
	20	TDP	TDP	TDP	TDP	TDP
	25	TTP	TDP	TDP	TDP	TDP
	30	TTTP	TTTP	TTP	TTP	TTTP
	35	TTTP	TTTP	TTTP	TTTP	TTTP
2 Titik Api	10	TDP	TDP	TDP	TDP	TDP
	15	TDP	TDP	TDP	TDP	TDP
	20	TDP	TDP	TDP	TDP	TDP
	25	TDP	TDP	TDP	TDP	TDP
	30	TTP	TDP	TDP	TDP	TTP
	35	TTP	TTP	TDP	TDP	TTP
3 Titik Api	10	TDP	TDP	TDP	TDP	TDP
	15	TDP	TDP	TDP	TDP	TDP
	20	TDP	TDP	TDP	TDP	TDP
	25	TDP	TDP	TDP	TDP	TDP
	30	TDP	TDP	TDP	TDP	TDP
	35	TTP	TDP	TDP	TDP	TDP

ket : TDP = Accurate and concise  
 TTP = Accurate but not concise  
 TTTP = Inaccurate and not concise

In this research, two parameters were used: the accuracy of the fire spot detection position and the success of extinguishing the fire spot. Each parameter is calculated using the formula in the equation(7).

$$\text{Accuracy} = \frac{TDP+TTP}{\text{Overall value of 1 condition}} \times 100\% \quad (7)$$

Thus, the accuracy value of this system is as follows:

$$\text{Accuracy of 1 fire points} = \frac{22}{30} \times 100\% = 73\%$$

$$\text{Accuracy of 2 fire points} = \frac{30}{30} \times 100\% = 100\%$$

$$\text{Accuracy of 3 fire points} = \frac{30}{30} \times 100\% = 100\%$$

The success of fire suppression can also be calculated using the equation (8).

$$\text{Suppression} = \frac{TDP}{\text{Overall value of 1 condition}} \times 100\% \quad (8)$$

The results of the fire suppression success calculation are as follows:

$$\text{Suppression of 1 fire point} = \frac{23}{30} \times 100\% = 76\%$$

$$\text{Suppression of 2 fire point} = \frac{25}{30} \times 100\% = 83\%$$

$$\text{Suppression of 3 fire point} = \frac{29}{30} \times 100\% = 96\%$$

#### IV. CONCLUSION

This automatic fire detection and extinguishing system using the dual axis principle has been successfully implemented and functions well. The tool model created can detect fire quite accurately and can extinguish the fire appropriately. The accuracy of spot fire detection reaches 73-100%, and the success rate ratio for extinguishing fires reaches 76-96%. The results prove that the design of the fire detection and extinguishing system in this research is suitable for application in room or building conditions that require early anticipation of fire, with adjustments to the sensors used that need to be replaced with other types with a more extended range.

#### REFERENCES

- [1] M. Safarudin dan A. Patah, "Pengembangan Purwarupa Robot Pemadam Api Dengan Kendali Berbasis Mikrokontroler," *Isu Teknol. Stt Mandala*, vol. 15, no. 2, hal. 92–98, 2020.
- [2] R. Darwis, I. Arifianto, A. Mujadin, dan S. Rahmatia, "Perancangan Robot Pemadam Api Hexapod," *J. Al-AZHAR Indones. SERI SAINS DAN Teknol.*, vol. 5, no. 1, hal. 1, 2019, doi: 10.36722/sst.v5i1.316.
- [3] N. S. Rohimah, Muhaimin, "Rancang Bangun Robot Pemadam Api Otomatis Menggunakan Sistem Pneumatik," *J. TEKTR0*, vol. 04, no. 1, hal. 31–37, 2020.
- [4] M. D. D. Rezaputra dan M. R. A. Cahyono, "Perancangan Sistem Kontrol Otomatis Press Roll Berbasis PLC Mitsubishi Type-Q Pada Building Tire Machine," *Indones. J. Eng. Technol.*, vol. 3, no. 2, hal. 92–101, 2021, doi: 10.26740/inajet.v3n2.p92-101.
- [5] B. A. Nugroho dan Y. M. Djaksana, "Implementasi Mikrokontroler Arduino Uno dan

- Multi Sensor Pada Tempat Sampah,” *J. Sci. Sacra J. Sains*, vol. 2, no. 4, hal. 70–77, 2022.
- [6] A. S. Kvalsund dan D. Winkler, “Development of an Arduino-based, open-control interface for hardware in the loop applications,” *HardwareX*, vol. 16, hal. e00488, Des 2023, doi: 10.1016/j.ohx.2023.e00488.
- [7] M. Sefriza Toriq Hidayat dan W. D. Kurniawan, “Analisa Perbandingan Sistem Kontrol Berbasis Arduino Dan Plc Pada Pengendalian Suhu,” *J. Rekayasa Mesin*, vol. 07, no. 02, hal. 24–28, 2022.
- [8] I. Nugrahanto, S. Sungkono, dan E. Mandayatma, “Analisis Arus Konstan Pada Solar Cell Dengan Pengaturan Dual Axis Tracking,” *E-Link J. Tek. Elektro dan Inform.*, vol. 16, no. 2, hal. 54, 2021, doi: 10.30587/e-link.v16i2.3081.
- [9] R. Khotama, D. B. Santoso, dan A. Stefanie, “Perancangan Sistem Optimasi Smart Solar Electrical pada Pembangkit Listrik Tenaga Surya (PLTS) dengan Metode Tracking Dual Axis Technology,” *J. Ecotipe (Electronic, Control, Telecommun. Information, Power Eng.)*, vol. 7, no. 2, hal. 78–84, 2020, doi: 10.33019/jurnalecotipe.v7i2.1887.
- [10] M. R. Dewanto, Y. T. K. Priyanto, Thomas Dwi Putra Salim, Mohammad Khatami, dan Sena Sukmananda Suprpto, “Perancangan Dual-Axis Solar Tracker untuk PLTS dengan Analisis Pengaruh Jumlah Sensor dan Tracking Delay,” *J. Sistim Inf. dan Teknol.*, vol. 4, hal. 204–208, 2022, doi: 10.37034/jsisfotek.v4i4.181.
- [11] H. Setiana, A. Bening Kusumaningtyas, dan R. Maulana, “Rancang Bangun PLTS Solar Tracker Dual Axis Berbasis IoT Menggunakan ESP32,” *Pros. SENIATI*, vol. 7, no. 2, hal. 177–182, 2023, doi: 10.36040/seniati.v7i2.7944.
- [12] Y. S. Adi Octa Pradana, Patia Welly Sirait, “Pemanfaatan Solar Tracker Dual Axis Berbasis Iot Pada Fotovoltaik Polikristalin,” *RELE (Rekayasa Elektr. dan Energi) J. Tek. Elektro*, vol. 6, no. 1, hal. 42–49, 2023, doi: 10.30596/rele.v6i1.15462.
- [13] P. Muthukumar, S. Manikandan, R. Muniraj, T. Jarin, dan A. Sebi, “Energy efficient dual axis solar tracking system using IOT,” *Meas. Sensors*, vol. 28, hal. 100825, Agu 2023, doi: 10.1016/j.measen.2023.100825.
- [14] D. Kurnia, R. Mardiaty, M. R. Effendi, dan A. E. Setiawan, “Rancang Bangun Robot Pemadam Api Menggunakan Kontrol Bluetooth dan Virtual Reality,” *TELKA - Telekomun. Elektron. Komputasi dan Kontrol*, vol. 5, no. 2, hal. 139–146, 2019, doi: 10.15575/telka.v5n2.139-146.
- [15] S. M, K. Kamal, M. Rizal, dan A. Syani, “Rancang Bangun Robot Cerdas Pemadam Api Menggunakan Teknik Navigasi Wall Follower Berbasis Arduino,” *ILTEK J. Teknol.*, vol. 17, no. 02, hal. 88–93, 2022, doi: 10.47398/iltek.v17i02.16.
- [16] A. Eddy Irvine dan A. Musafa, “Sistem Tracker Single Axis Solar Concentrator Pada Pembangkit Listrik 2 Watt Bertenaga Panas Matahari,” *J. Maest.*, vol. 6, no. 2, hal. 303–312, 2023.
- [17] T. Wahyudi, S. F. Fiddin, D. A. Utama, dan ..., “Implementasi Alat Pendeteksi Dini Kebakaran di Kelurahan Bukit Duri Berbasis Internet of Things (IoT),” *J. Komunitas ...*, vol. 5, no. 2, hal. 250–258, 2023.
- [18] A. Sundaram, H. Zuhair, dan A. Garni, “A Smart Garden System with a Dual-Axis Solar Tracker,” *Int. J. Adv. Sci. Technol.*, vol. 29, no. 8, hal. 1390–1397, 2020.
- [19] E. P. Dekki Widiatmoko, Rachmat Setiawibawa, Rafi Maulana Al-farizi, Mokhammad Syafaat, “Implementasi Sensor LDR Pada Prototipe Sistem Tracking Dual Axis Untuk Deteksi Arah Sinar Matahari Pada Sel Surya Implementation Of The LDR Sensor In The Dual Axis Tracking System Prototype For Detecting The Direction Of Sunlight On Solar Cells Jurusan El,” *Aspir. Publ. Has. Pengabd. dan Kegiat. Masy.*, vol. 1, no. 5, 2023.
- [20] P. Pawar, P. Pawale, T. Nagthane, M. Thakre, dan N. Jangale, “Performance enhancement of dual axis solar tracker system for solar panels using proteus ISIS 7.6 software package,” *Glob. Transitions Proc.*, vol. 2, no. 2, hal. 455–460, 2021, doi: 10.1016/j.gltp.2021.08.049.